

"Edge of Dock" Submittal Drawing

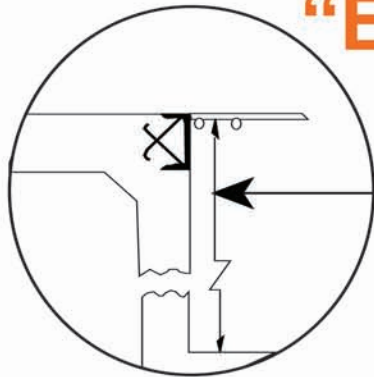

SECTION DETAIL

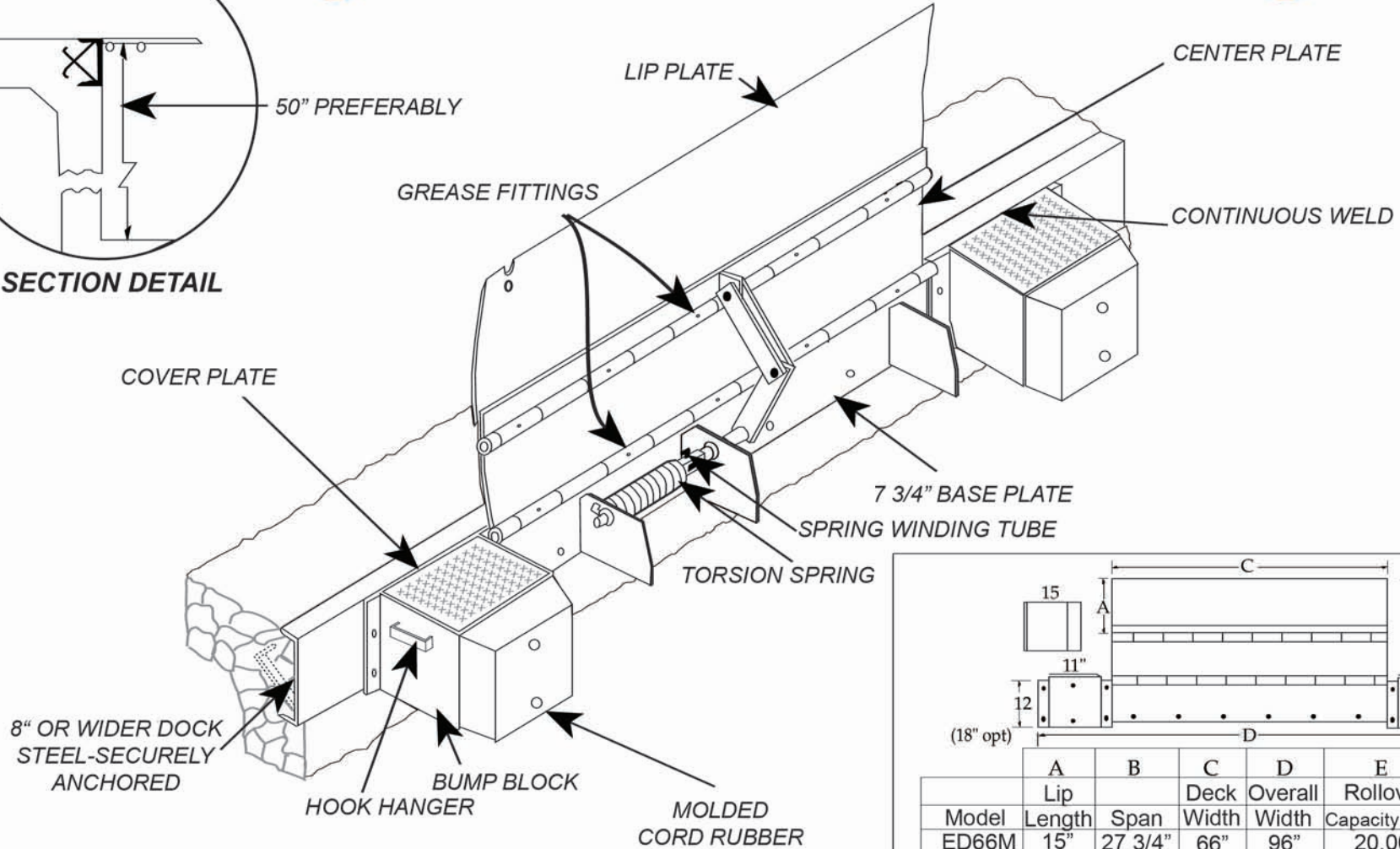

NOTES: Deck & Lip - 55,000 lb. min. yield steel.
30,000 lb Capacity in stored position. Units include C1045 cold rolled 11/16" rod and cold drawn seamless tubing (1-1/4" OD, 5/16" wall).

	A	B	C	D	E	F
	Lip	Span	Deck	Overall	Rollover	Plate
Model	Length	Span	Width	Width	Capacity Lbs.	Thickness
ED66M	15"	27 3/4"	66"	96"	20,000	3/8"
ED66MH	15"	27 3/4"	66"	96"	25,000	7/16"
ED66M-17	17"	29 3/4"	66"	96"	20,000	3/8"
ED72M	15"	27 3/4"	72"	102"	20,000	3/8"
ED78M	15"	27 3/4"	78"	108"	20,000	3/8"
ED84M	15"	27 3/4"	84"	114"	20,000	3/8"

SPECIFY JOB REQUIREMENTS FROM

--	--	--	--	--	--	--



PO Box 338 • Spring Hill, Tennessee 37174
 931.486.2296 • 800.251.3382 • Fax: 931.486.0316
www.pioneerleveler.com

JOB

"ED66M" Adaptor Kit Assembly

ADAPTOR KIT ASSEMBLY ED66M

ED66M Kit, Part #192, consists of the following:

ITEM	DESCRIPTION
7	TorsionSpring
8	Spring winding tube assembly
9	Torsion arm & linkage assembly
10	Gusset with bearing
11	Bearing, torsion arm
12	Gusset with retainer
13	Gussett
14	Lip linkage tab
15	Lip linkage arms (2 ea. req.)
16	Linkage pins (2 ea. req.)
17	Cotter Keys (2 ea. req.)

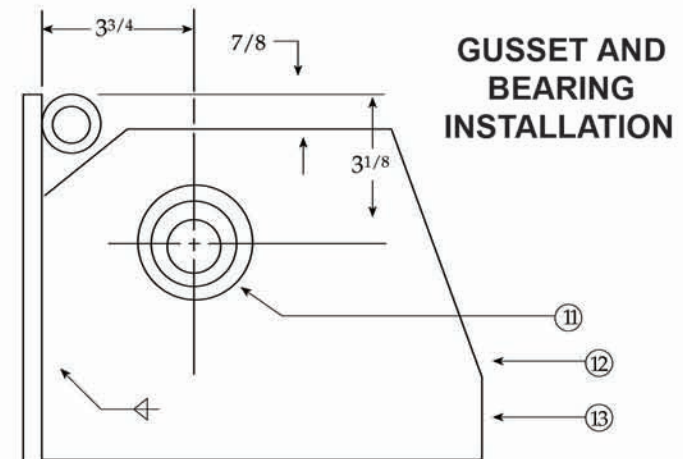
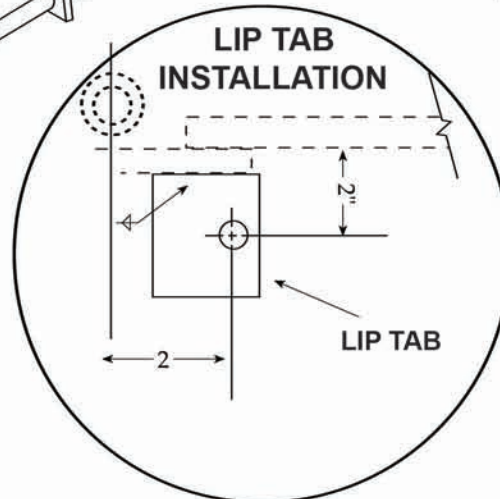
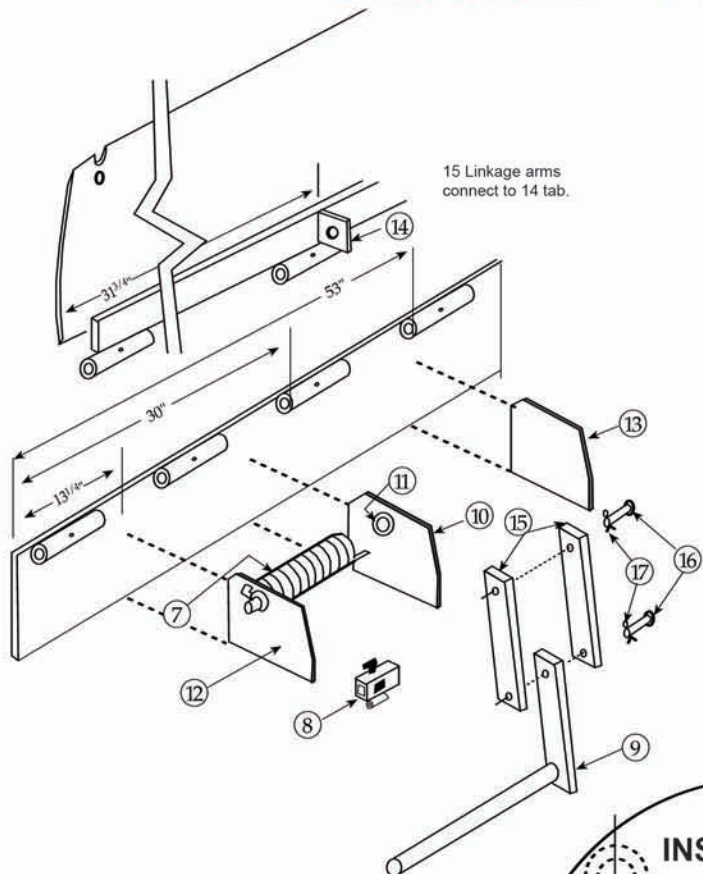

PO Box 338 • Spring Hill, Tennessee 37174
931.486.2296 • 800.251.3382 • Fax: 931.486.0316
www.pioneerleveler.com