

# "P2000" Series Submittal Drawing

## "P2000" SERIES MECHANICAL DOCK LEVELER MODEL SPECIFICATIONS

MODEL	LIP*	DECK**	NOMINAL LENGTH	WIDTH	HINGE CF1045	SEAMLESS HINGE TUBE	OPERATING RANGE
P26625,30 / P27625,30	1/2" x 16"	1/4"	6'	72"/83"	1" diameter	1 5/8" dia. O.D.	+ 12" - 12"
P26825,30 / P27825,30	1/2" x 16"	1/4"	8'	72"/83"	1" diameter	1 5/8" dia. O.D.	+ 12" - 12"
P26635,40,45 / P27635,40,45	5/8" x 16"	1/4"	6'	72"/83"	1 1/8" diameter	2" dia. O.D.	+ 12" - 12"
P26835,40,45 / P27835,40,45	5/8" x 16"	1/4"	8'	72"/83"	1 1/8" diameter	2" dia. O.D.	+ 12" - 12"
P261025,30 / P271025,30	1/2" x 16"	1/4"	10'	72"/83"	1" diameter	1 5/8" dia. O.D.	+ 16" - 16"
P261035,40,45	5/8" x 16"	1/4"	10'	72"	1 1/8" diameter	2" dia. O.D.	+ 16" - 16"
P271035,40,45	5/8" x 16"	1/4"	10'	83"	1 1/8" diameter	2" dia. O.D.	+ 16" - 16"

### INSERT SPECIFIC JOB REQUIREMENTS FROM CHART

--	--	--	--	--	--	--	--

STANDARD CAPACITY

A.N.S.I. CAPACITY

--	--

\* Reinforced lip hinge. \*\*\*Lip and deck, 55,000 lb. minimum yield steel; \*\*\* Models with deck width of 78" (6 1/2') are available upon request.  
 WARRANTY: 3 years on structural members & main springs; 1 year on mechanical & misc. parts (includes materials, labor & freight).

### OPTIONAL FEATURES

- Lip 18"
- Lip 20"
- Weather Seals (side & rear)
- Hydra-Lip (lip closes quietly)
- Full Range Toe Guards
- Foam Insulation
- Abrasive Deck
- Yellow & Black Diagonal Safety Stripe on Toe Guards
- Below Dock Control
- Laminated Bumpers size \_\_\_\_\_

### STANDARD FEATURES

- (2) Molded Bumpers
- Lip 16"
- Grease Fittings
- Working Range Toe Guards
- Dual Safety Legs
- Dual 60,000 lb. Safety Legs
- Direct Extension Spring Counter Balance (no moving parts)
- Lip Keeper / Night Locks
- Maintenance Strut
- Full Length Structural "C" Channel Deck Support



NOTES

JOB

P.O. Box 338 • Spring Hill, Tennessee 37174  
 931/486-2296 • 800/251-3382 • Fax: 931/486-0316  
 www.pioneerleveler.com

# "P2000" Series Pit Detail

08/06

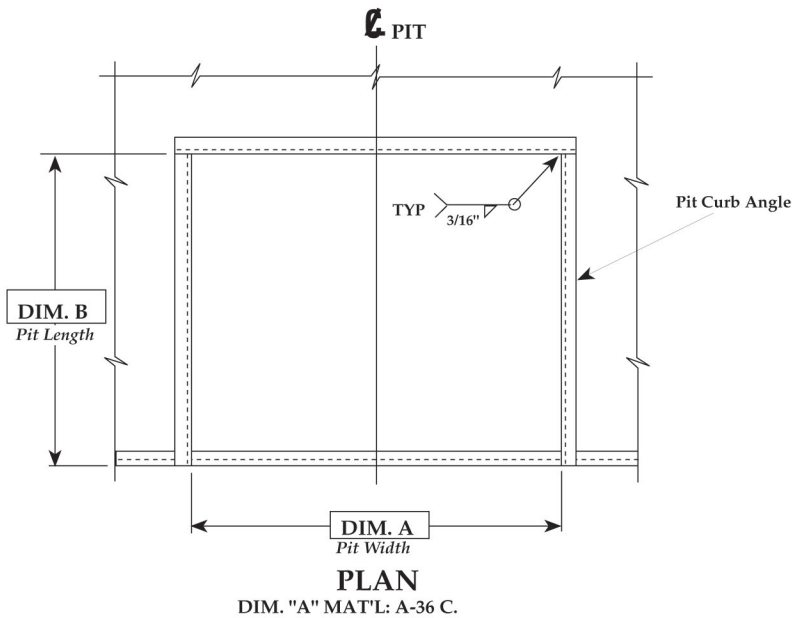

VARIABLE DIMENSIONS				
MODEL	"A"	"B"	"C"	"D"
6'W x 6'L	74"	63"	19 1/2"	20"
6'W x 8'L	74"	87"	19 1/2"	20"
6'-6"W x 6'L	80"	63"	19 1/2"	20"
6'-6"W x 8'L	80"	87"	19 1/2"	20"
7'W x 6'L	85"	63"	19 1/2"	20"
7'W x 8'L	85"	87"	19 1/2"	20"
6'W x 10'L	74"	111"	23 1/2"	24"
6'-6"W x 10'L	80"	111"	23 1/2"	24"
7'W x 10'L	85"	111"	23 1/2"	24"

INSERT SPECIFIC JOB DIMENSIONS FROM CHART

--	--	--	--	--

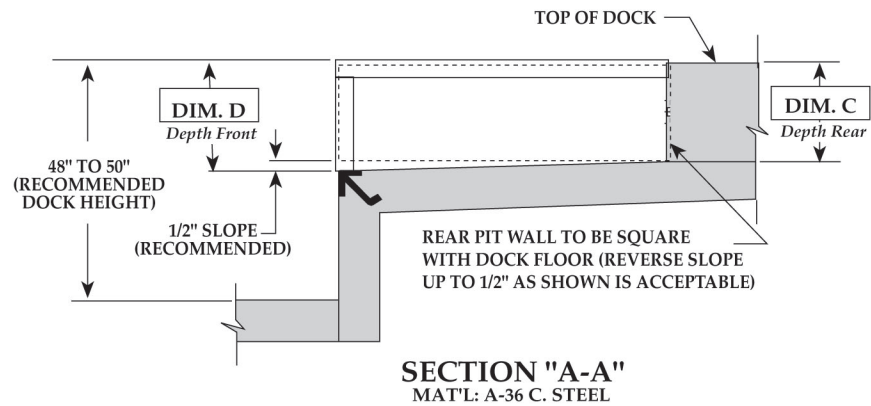
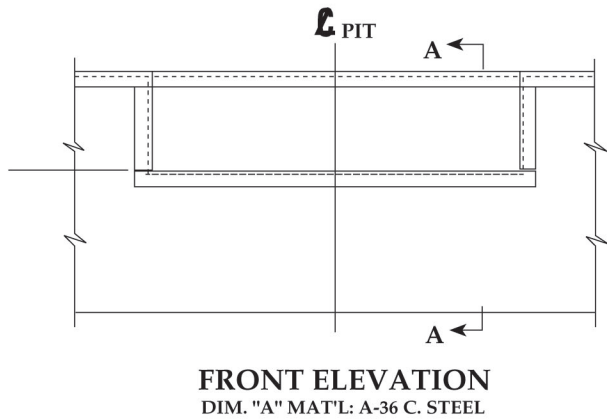

NOT TO SCALE



P.O. Box 338 • Spring Hill, Tennessee 37174  
931/486-2296 • 800/251-3382 • Fax: 931/486-0316  
www.pioneerleveler.com

NOTES

JOB

DRAWN:	SCALE:	DATE:	DRAWING NUMBER:
D.E.A.	AS NOTED	9/30/94	PMI-2014-R1

<b>TOLERANCES:</b>		
Inch Dimension =	Decimal Dimension =	Angles =
1/16"	±.005	1°